

**OPERATOR'S
SPARE PARTS &
SERVICE MANUAL**



PLATE COMPACTOR MODEL FPCL350 – FPCL450 (GB Version)



FAIRPORT

CONSTRUCTION EQUIPMENT LTD

Blagden Street
Sheffield
S2 5QS
ENGLAND
Tel: +44 (0) 114 276 7921
Fax: +44 (0) 114 272 0965
Email: sales@fairport.uk.com
Web: www.fairport.uk.com

CONTENTS

PAGE

1.	SAFETY	2
	SAFETY PICTOGRAMS USED ON FAIRPORT EQUIPMENT	2
	LABEL LOCATIONS	3
2.	TECHNICAL DATA	4
3.	USING THE MACHINE FOR THE FIRST TIME	5
4.	ROUTINE MAINTENANCE	5
5.	STARTING THE ENGINE	6
6.	OPERATOR INSTRUCTIONS	6
7.	VEE BELT ADJUSTMENT	6
	PARTS LISTS:	
8.	MACHINE DRIVE	7
9..	MACHINE	8
10.	BASEPLATE	11
11.	WATER BOTTLE	13
12.	WARRANTY CONDITIONS AND CLAIMS PROCEDURE	15
13.	REPAIRS AND ESTIMATES	16
14.	ENVIRONMENT	16
15.	EC DECLARATION OF CONFORMITY.	17

1. SAFETY

- Do not operate this machine unless all guards are in position and secure.
- Do not smoke when refuelling.
- Do not refuel with engine running.
- Wipe up spilt fuel.
- Do not overfill.
- Dispose of fuel contaminated wipes safely
- Do not run engine in enclosed areas without adequate ventilation.
- Do not run engine in an area that has a hazardous or explosive atmosphere.
- Disconnect H.T. lead from spark plug on petrol engines before carrying out any maintenance.
- Turn off fuel when not using machine.
- Wear protective footwear, ear defenders and gloves.
- Comply with site safety regulations.
- Check condition and tightness of anti-vibration mounts between engine plate and base plate before lifting.

SAFETY PICTOGRAMS USED ON FAIRPORT EQUIPMENT



LABEL LOCATIONS

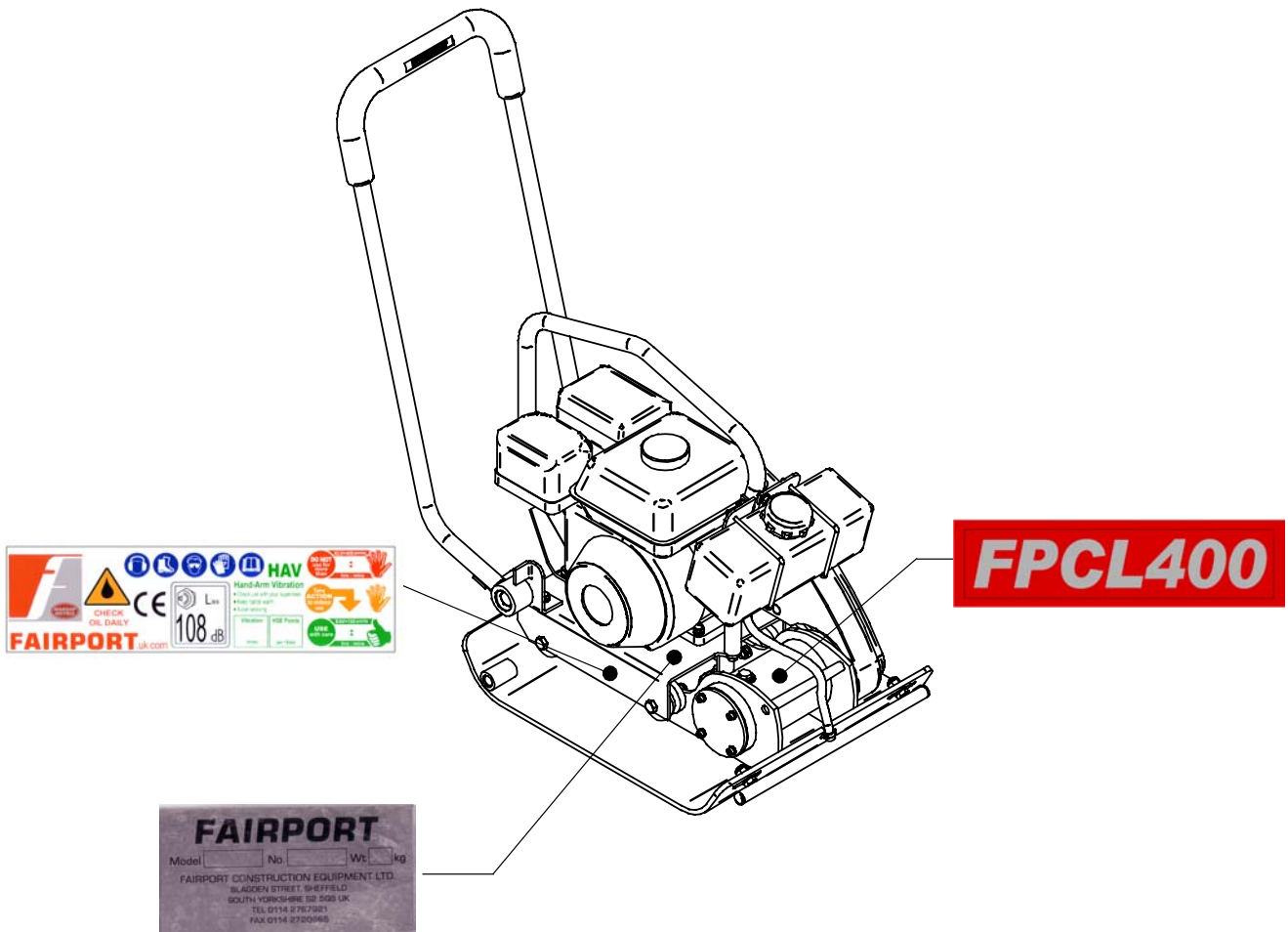

2. TECHNICAL DATA

ENGINE

MODEL	ENGINE MANUFACTURER	ENGINE MODEL	POWER (HP/kW)
FPCL350	Honda	GX160	5.5/4.0
FPCL400	Honda	GX160	5.5/4.0
FPCL450	Honda	GX160	5.5/4.0

DIMENSIONS

MODEL	HEIGHT – H (mm)	LENGTH – L (mm)	WIDTH – W (mm)	CONTACT AREA (sq. m)	WEIGHT (kg)
FPCL350	690	773	350	0.13	
FPCL400	690	773	400	0.14	
FPCL450	690	773	450	0.16	

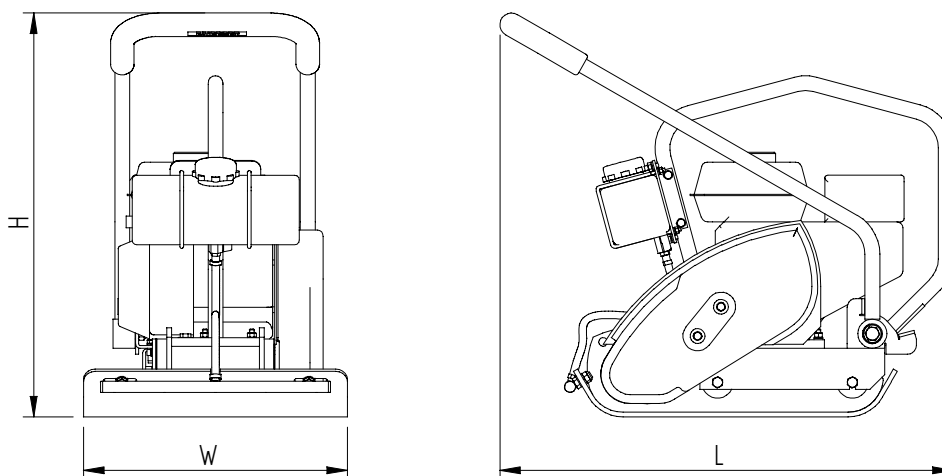

PERFORMANCE

MODEL	CENTRIFUGAL FORCE (kN)	COMPACTION RATIO (kg/m ²)	VIBRATION LEVELS (m/sec ²)
FPCL350	14		*
FPCL400	14		*
FPCL450	14		*

*Tested in accordance with BS EN 500-4 on uncompacted granular sub base materials and is the minimum expected level.

NOISE EMISSIONS

MODEL	GUARANTEED SOUND POWER LEVEL (dB Lwa)
FPCL350	108
FPCL400	108
FPCL450	108

3. USING THE MACHINE FOR THE FIRST TIME

When the machine is delivered from Fairport it will have **no oil in the engine**. Please refer to the Engine Manufacturers Manual issued with the machine for instructions on filling the engine with the correct type and quantity of oil.

When the machine is delivered from Fairport **there is oil in the vibrator unit**. Refer to Section 4 for advise on checking the oil level and topping up as required.

4. ROUTINE MAINTENANCE

(See Also The Engine Manufacturers Manual issued with the machine)

Daily: Check engine oil level twice daily.
Check tightness of all fastenings after first days use, thereafter check monthly.
Check belt tension after first days use, thereafter check monthly.
Clean air filter daily if working in dusty conditions.
Clean base plate thoroughly if compacting black-top or lean concrete.

Weekly: Clean air filter (see “daily”).
Check Vibrator Oil level.

Monthly: Check tightness of fastenings.
Check condition and tightness of anti-vibration mounts. Poor condition of vibration mountings can lead to a deterioration of the product vibration levels.
Check belt tension.

Vibrator Unit

Remove the Oil Level Plug to check the oil level. The level should be at the bottom of the thread in the vibrator end face. To top up, remove the filler plug and fill with Total PRESLIA 32 or equivalent.

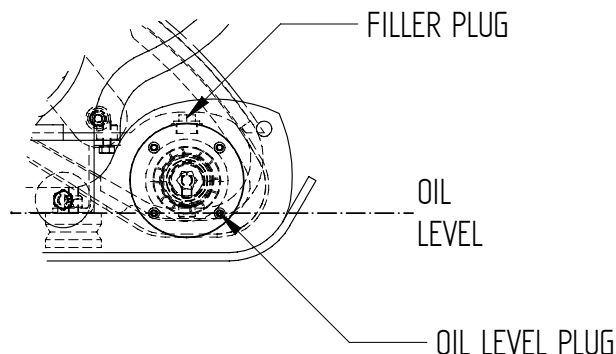

5. STARTING THE ENGINE

Check oil level.

Turn fuel tap on.

Put speed control lever to tick-over.

If engine is cold, close the choke (petrol engines only).

Turn engine switch to ON(1) position.

Pull the starter rope toggle lightly until resistance is felt, then pull briskly using quick short pull. Do not pull rope to its full extent or allow toggle to snap back against engine. Return gently to avoid damage.

When the engine is warm, open choke.

Position engine speed control lever to give required engine speed (usually full speed).

Commence vibration – the compactor is self – travelling.

To stop the engine, position the engine speed control to slow and turn the engine switch to off(0).

Turn the fuel valve off.

6. OPERATOR INSTRUCTIONS

Read section (1) - Safety.

NOTE: Drive between engine and vibrator is through a centrifugal clutch. Vibration will commence as engine speed is increased.

Position the engine speed control lever to give required speed (usually full speed).

Commence compaction. The compactor is self-travelling. Its speed of travel and the number of passes required to achieve optimum compaction depends on the type and condition of material being compacted and the layer depth.

Uniformly graded granular material compacts far more efficiently than wet cohesive material.

When Compacting block paving always use a rubber attachment mat, contact your agent for details.

When compacting blacktop always use a water spray, contact your agent for details.

Do not run the machine on solid surfaces, as this is likely to cause damage.

7. VEE BELT ADJUSTMENT

It is important to note that belt tension in this application is much less than is generally accepted as normal. Too high a belt tension may lead to engine damage, excessive vibration in the handle, short belt life and short vibrator shaft bearing life due to excessive transmission of vibration through the belt. Correct adjustment is achieved by moving the engine back to just take the slack out of the belt. With light finger pressure on top of the belt and at the centre of the span, a deflection of between 5mm and 10mm is expected.

8. PARTS LIST – MACHINE DRIVE SYSTEM

<u>Parts List</u>	<u>Part Code</u>	<u>Description</u>	<u>Qty Required</u>
1	W14702	Belt Guard	1
2	W87300	Vee Belt	1
3	W87060	Clutch	1
4	P80167	1/4 UNF x 1" Setscrew	1
5	W432/6	M6 Spring Washer	1
6	P80120	Retaining Washer	1
7	W14689	Belt Guard Back Plate	1
8	W14681	Engine Spacer	1
9	W466/5/12	5/16" UNF x 3/4" CSK	4
10	W437/8/20	M8 x 20 Setscrew	2
11	W432/8	M8 Spring Lock Washer	2
12	W418/8	M8 Washer	2
13	-----	Engine Shaft Key (With Engine)	1

PARTS DIAGRAM- MACHINE DRIVE SYSTEM

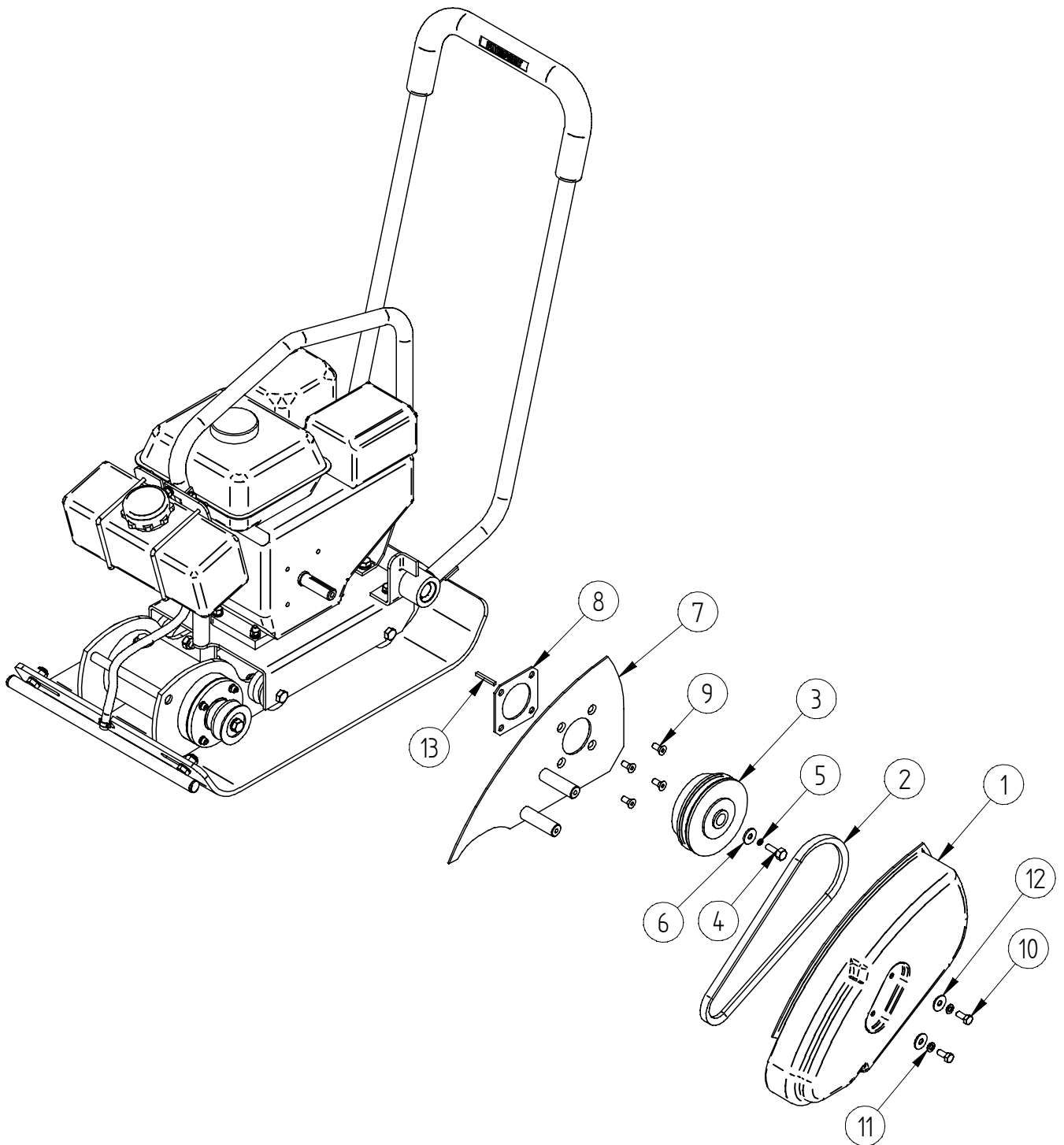

9. PARTS LIST – MACHINE

<u>Parts List</u>	<u>Part Code</u>	<u>Part Description</u>	<u>Qty Required</u>
1	W14771	Handle	1
2	W81731	Honda GX160	1
3	W14640	Engine Bed Plate	1
4	W14686	Engine Fixing Plate	2
5	W418/8	M8 Washer	13
6	W437/8/45	M8 x 45 Hex Setscrew	4
7	W440/8	M8 Nut	4
8	W432/8	M8 Spring Lock Washer	9
9	W88914	AV Buffer	1
10	W418/10	M10 Washer	3
11	W432/10	M10 Spring Lock Washer	3
12	W440/10	M10 Nut	1
13	W437/10/30	M10 x 30 Hex Setscrew	2
14	W14775	Lifting Assy	1
15	W88912	Handle Bush	2
16	W14683	Handle Pivot Bolt	2
17	W480/12	M12 Nyloc Nut	2
18	W14774	Handle Bracket – RH	1
19	W14773	Handle Bracket – LH	1
20	W14772	Fixing Bar	1
21	W437/8/25	M8 x 25 Hex Setscrew	1
22	W437/8/30	M8 x 30 Hex Setscrew	4

PARTS DIAGRAM – MACHINE

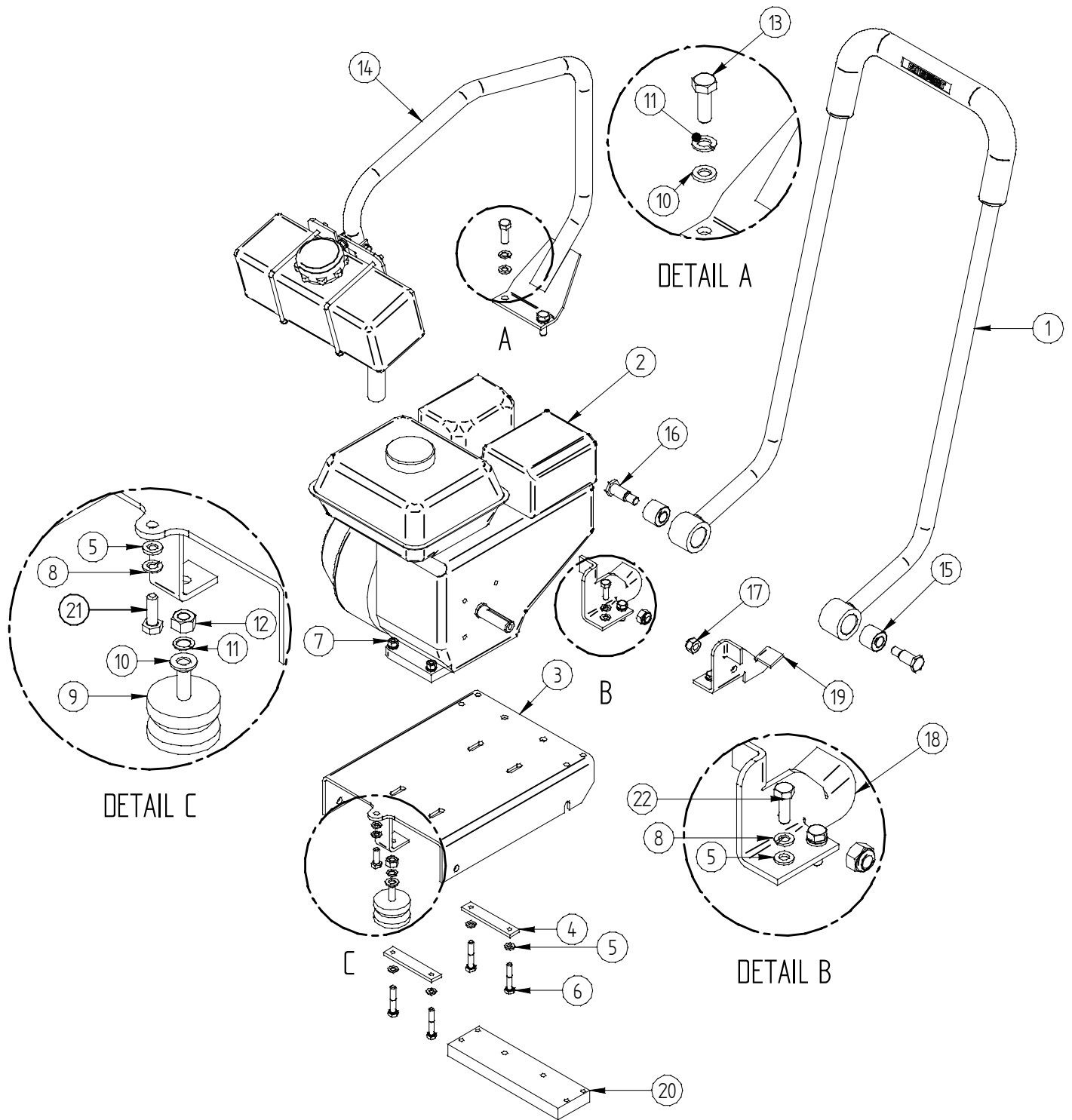

10. PARTS LIST – BASEPLATE ASSEMBLY

<u>Parts List</u>	<u>Part Code</u>	<u>Description</u>	<u>Qty Required</u>
1	W14653	End Cap	1
2	W14679	Neoprene Gasket	2
3	W81090	Bearing	2
4	W14661-2	Eccentric Weight	1
5	W14764	Base (FPCL350)	1
5	W14765	Base (FPCL400)	1
5	W14658	Base (FPCL450)	1
6	W87301	Key 8 x 7 x 15	1
7	W81271	Oil Seal	1
8	W14707	End Cap	1
9	W14656	Pulley	1
10	W435/10/40	Hex Bolt M10 x 40	1
11	W68574	Filler Cap	1
12	W418/10	M10 Washer	1
13	W535/10	M10 Nordlock Washer	1
14	W455/10/30	M10 x 30 Socket Head Cap Screw	2
15	W14705	Eccentric Shaft	1
16	P85034	Dowty Washer	1
17	W432/10	M10 Spring Lock Washer	1
18	W455/6/18	M6 x 18 Socket Head Cap Screw	8
19	W432/6	M6 Spring Lock Washer	7
20	P70282	Dowty Washer	1
21	W437/10/18	M10 x 18 Hex Setscrew	4
22	W432/10	M10 Spring Lock Washer	8
23	W88911	AV Mount AVM 2312s/38	4
24	W418/10	M10 Washer	4
25	W440/10	M10 Nut	4

PARTS DIAGRAM – BASEPLATE ASSEMBLY

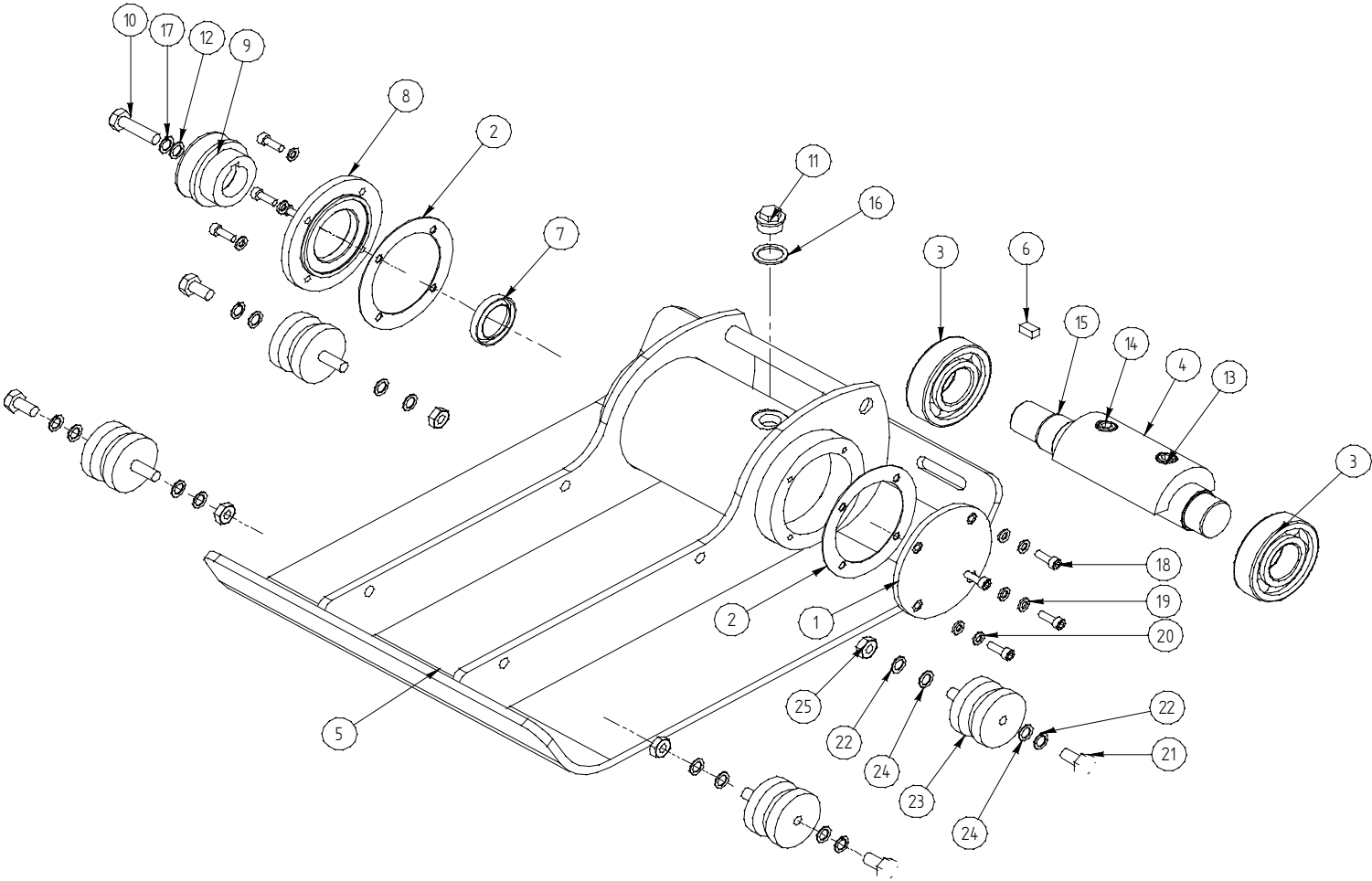

11. PARTS LIST – WATER BOTTLE ASSY

<u>Parts List</u>	<u>Part Code</u>	<u>Part Description</u>	<u>Qty Required</u>
1	W14775	Lifting Assy	1
2	W55031	Water Bottle	1
3	W420/6	M6 Washer	4
4	W432/6	M6 Spring Washer	4
5	W440/6	M6 Plain Nut	4
6	W87857	¼ BSP Lock Nut	1
7	P83584	¼ BSP Bonded Seal	1
8	W55032	Tank Clamp	2
9	W87864	Ball Valve	1
10	P88046	Hose Tail	1
11	W480/6	M8 Nyloc Nut	2
12	W420/8	M8 Washer	6
13	W14697	Spray Bar (FPL350)	1
13	W14699	Spray Bar (FPL400)	1
13	W14701	Spray Bar (FPL450)	1
14	W14713	Water System Hose	1
15	W14777	Bottle Mount	2
16	W432/8	M8 Spring Washer	2
17	W437/8/20	M8 X 20 Hex Set	2
18	W437/8/45	M8 X 45 Hex Set	2
19	W480/10	M10 Washer	4
20	W480/10	M10 Nyloc Nut	2
21	W84189	'O' Clip	2

PARTS DIAGRAM – WATER BOTTLE ASSY

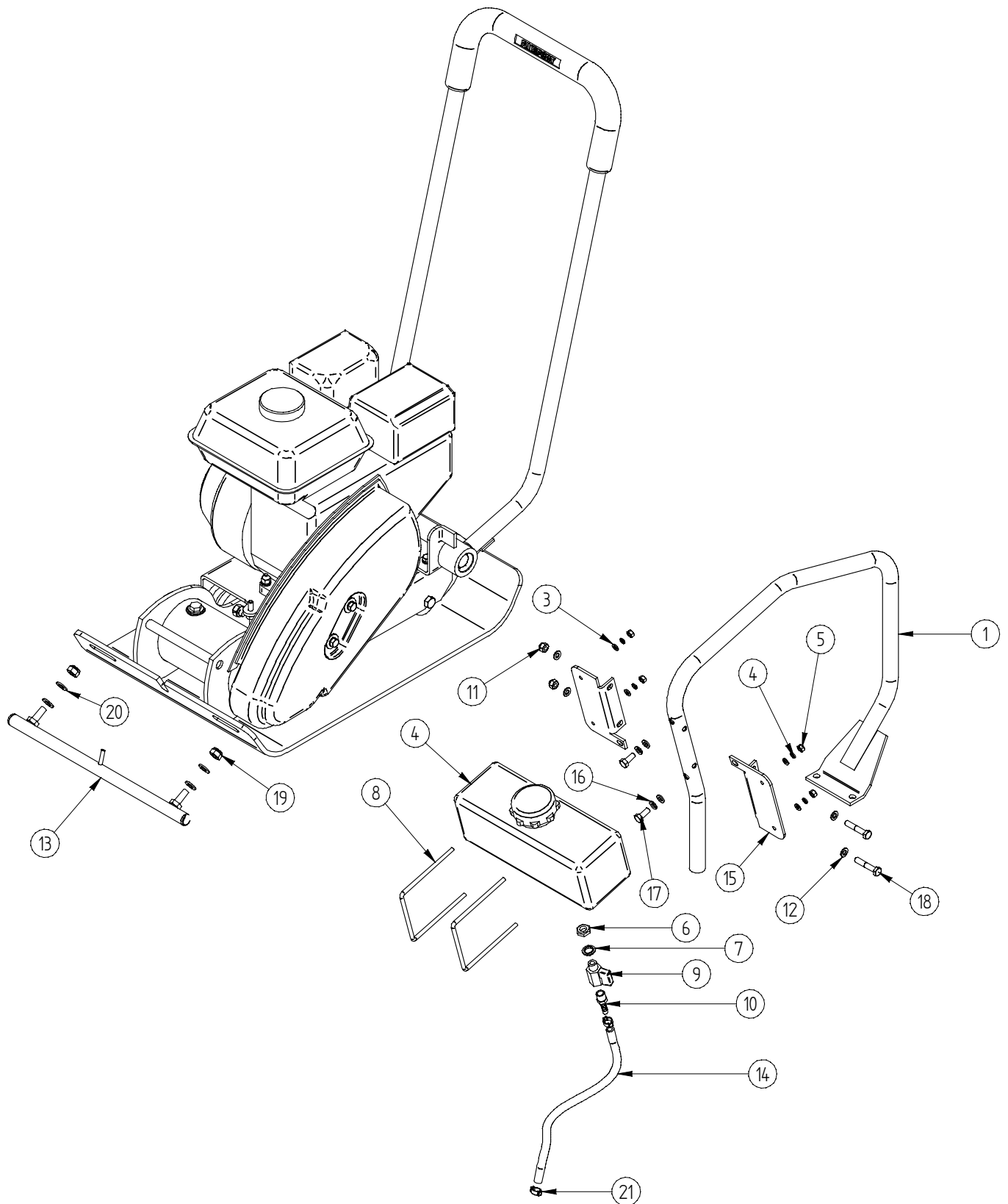

12. WARRANTY CONDITIONS AND CLAIMS PROCEDURE

All products supplied by Fairport Construction Equipment Ltd (hereafter referred to as FCE) are warranted to be free of defects due to faulty materials or workmanship for a period of 12 months from the date of original despatch from FCE or as specified below:

Hydraulic hoses and hydraulic couplings – 3 months.

Hydraulic accumulators – 6 months.

Flexible drives – 6 months.

All spare parts used in repairs carried out by FCE or an authorised dealer or repairer – 3 months.

If the goods have been purchased through a stockist the above warranty periods also apply from receipt of the goods by the user of the equipment up to a total of a further 6 months from date of despatch from FCE whichever is earlier.

Filter elements, gauges and oils are specifically excluded from this warranty.

FCE shall at their option repair or replace during normal working hours goods accepted as faulty free of charge to the user.

For proprietary items such as engines, the original manufacturer's warranty and conditions shall apply.

CONDITIONS

The goods shall be returned at the purchaser's expense to FCE or to a destination FCE may reasonably direct. Carriage costs will be refunded if warranty is accepted.

Warranty claims will not be considered where there is evidence that failure has been caused by carelessness, improper use, negligence, inadequate servicing, incorrect engine speeds, fair wear and tear or non-compliance with instructions issued by the manufacturer.

To the extent permitted by law, the liability of FCE under this section is confined only to providing a remedy for defective goods and does not extend to any consequential loss, loss of profit, injury or damage suffered.

Warranty will not be accepted on dismantled goods unless dismantling was carried out with the written permission of FCE.

No claim shall be considered if other than genuine parts supplied by FCE have been used.

Products are only covered by this warranty in the country to where they were supplied by FCE.

Warranty on products applies only to the original user of the equipment.

This warranty shall not apply if the serial number or other identifying numbers or marks applied by FCE have been removed, defaced or are otherwise illegible.

CLAIMS PROCEDURE

Check that the goods are still under warranty before returning them to FCE (see above for warranty periods).

Return the goods to FCE with an order number for the work to proceed. If warranty is accepted no charge will be made. If warranty is not accepted a quotation will be

given for the repair and the conditions under the section headed REPAIRS AND ESTIMATES will apply.

In the customer's interest, goods must be accompanied by documentation detailing the nature of the fault or its symptoms. Phrases such as 'Faulty' are unacceptable and will result in delays and possible charges to defray costs incurred in identifying the fault.

In the case of hydraulic breakers and power packs, both the breaker and the pack should be returned.

13. REPAIRS AND ESTIMATES

When returning a machine, or an assembly for repair, always include an Advice Note quoting model and serial number of the machine.

An official order must also be forwarded to FCE giving detailed instructions. No repair work can be carried out unless covered by an official order.

An estimate will be submitted before proceeding with any repair. To partly cover the cost in dismantling, cleaning and inspection, a small charge will be made, this however will be waived upon receipt of your official instructions to proceed with the repair.

In the event of the estimate not being accepted, a further charge will be made to defray the rebuilding of the machine.

Estimates must be treated as approximate only as it may be found necessary to use additional parts on further examination.

14. ENVIRONMENT

This machine contains materials that can be recycled. We recommend that when the machine is disposed off it is done safely and in a way that protects the environment.

Part Description	Materials
Engine	Aluminium and steel
Baseplate	Steel
Handle Mount	Steel
Engine Bedplate	Steel
Belt Cover	High Density Polyethylene
Handle	Steel and Polyurethane
Ant vibration Mounts	Steel and rubber
Block Paving Kit (if fitted)	Steel and Polyurethane
Water Bottle Kit (if fitted)	Steel and Medium Density Polyethylene

15. EC DECLARATION OF CONFORMITY

**WE, FAIRPORT CONSTRUCTION EQUIPMENT LTD, BLAGDEN ST, SHEFFIELD,
SOUTH YORKSHIRE, S2 5QS**

DECLARES THAT THE PRODUCT:

FPCL 350, 400 & 450; FITTED WITH A HONDA GX160 ENGINE

ENGINE POWER; 5.5HP/4.2kW at 3600RPM

SERIAL No.

.....

CONFORMS TO THE FOLLOWING DIRECTIVE:

89/336/EEC, 89/392/EEC, 91/368/EEC, 2000/14/EC

NOTIFIED BODY; **AV Technology Ltd, AVTECH House, Birdhall Lane, Cheadle
Heath, Stockport, Cheshire. SK3 0XU. GB.**

USES THE FOLLOWING STANDARDS:

BS EN 12100-1, BS EN 12100-2, BS EN 294, BS EN 500-4

CONFORMS TO THE FOLLOWING STATUTORY INSTRUMENTS

**THE SUPPLY OF MACHINERY (SAFETY) REGULATIONS 1992 &
AMMENDMENTS**

COMPLIES WITH THE RELEVANT ESSENTIAL HEALTH & SAFETY
REQUIREMENTS OF THE MACHINERY DIRECTIVE

DECLARATION

**I certify that on completion of manufacture of the machine detailed above that a
full conformity has been completed and relevant Health and Safety
Requirements complied with.**

NAME: **IAN MORRIS**

STATUS WITHIN COMPANY: **TECHNICAL MANAGER**

SIGNATURE:

